

The Steam module is designed for Pyroprobe 6200 to introduce water vapor at a user-settable rate into the DISC chamber under ambient pressure to introduce hydrolysis reaction between water and long chain polymer.

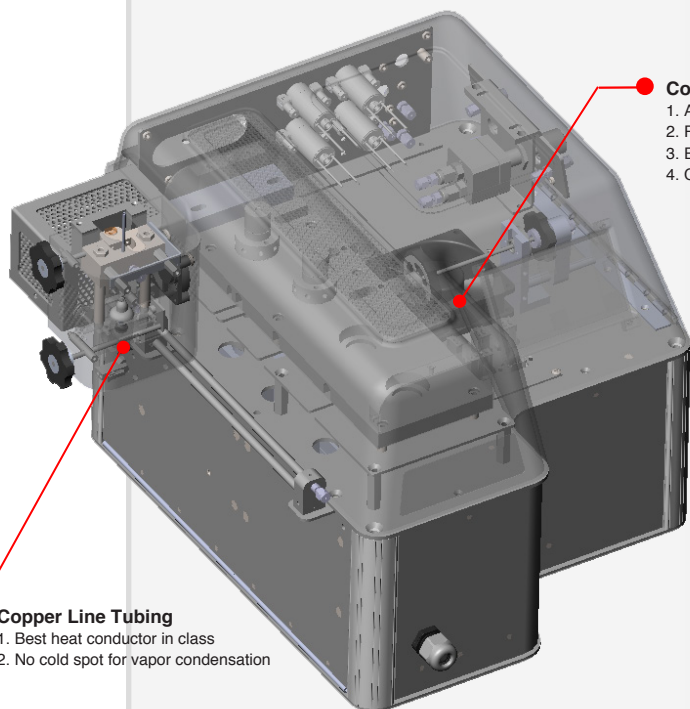

Compatible with Other Modules

1. Autosampler
2. Reactant gas
3. External catalyst reactor
4. Cryotrap



Copper Line Tubing

1. Best heat conductor in class
2. No cold spot for vapor condensation

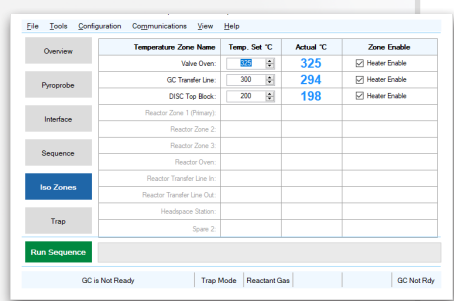

Seamless integration to the Pyroprobe DCI

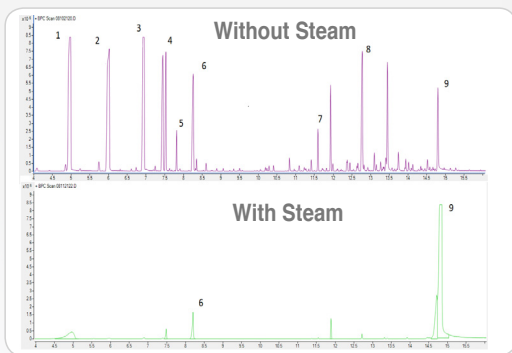

Pyrolysis of Lexan at 70°C per minute to 800°C

Peak Identification

- | | |
|---------------------|---------------------------------------|
| 1 Phenol | 6 p-Isopropenylphenol |
| 2 p-Cresol | 7 Diphenyl carbonate |
| 3 Phenol, 4-ethyl- | 8 Phenol, 4-(1-methyl-1-phenylethyl)- |
| 4 p-Cumenol | 9 Bisphenol A |
| 5 Phenol, 4-propyl- | |

Recommended Settings for Steam Option:

	Steam Option
Oven Temperature	325 °C
DISC Top Block	200 °C
DISC Interface	300 °C
Water Flow	0.05 ml/min in the pump setting equal to 50 ml/min H ₂ O vapor flow